

SC series

肘节型

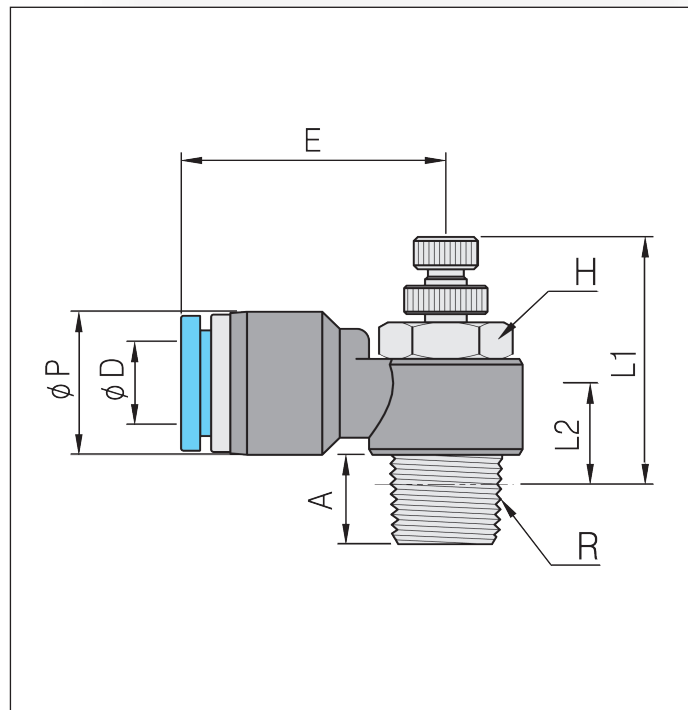

型号	ϕD	R (Thread)	ϕP	A	E	H	L1 (Max)	L2	Q'TY/BOX
SC04M5	4	M5	11	3.5	21.5	8	27	9	50
SC0401		Rc1/8	11	7	22	12	34	10	50
SC0402		Rc1/4	11	10	23	14	40	11	50
SC06M5	6	M5	13	3.5	22	8	27	9	50
SC0601		Rc1/8	13	7	23.5	12	34	10	50
SC0602		Rc1/4	13	10	25	14	40	11	50
SC0603		Rc3/8	13	11	25.5	19	46	13.5	25
SC0604		Rc1/2	13	14	31	24	50	15.7	25
SC0801	8	Rc1/8	15	7	26	12	34	10	50
SC0802		Rc1/4	15	10	28	14	40	12	50
SC0803		Rc3/8	15	11	31.3	19	44	13.5	25
SC0804		Rc1/2	15	14	31	24	50	15.7	20
SC1001	10	Rc1/8	18.4	7	30	12	34	12.5	50
SC1002		Rc1/4	18.4	10	32.5	14	40	11	50
SC1003		Rc3/8	18.4	11	33	19	44	14	25
SC1004		Rc1/2	18.4	14	35.5	24	50	15.7	20
SC1202	12	Rc1/4	21	10	33	14	40	15	25
SC1203		Rc3/8	21	11	35	19	44	15.5	25
SC1204		Rc1/2	21	14	38	24	49	16.5	20