

# KCXS series

双轴气缸/DUAL-rod cylinder

φ6 φ10 φ15 φ20 φ25 φ32



## 规格/Specification

内径 (mm)	6	10	15	20	25	32
作动方式/Acting	双动型					
工作介质/Fluids	洁净空气					
使用压力/Pressure range	0.15~0.7	0.1~0.7MPa		0.05~0.7MPa		
耐压力/Pressure-Resistance	1.05MPa					
工作温度/Fluids temp	-10~+60℃					
速度范围/Speed range (mm/s)	30~300	30~800	30~700		30~600	
行程调整/Stroke length tolerance	缩回行程: 0~5mm					
缓冲型式/Cushion type	两端橡胶缓冲					
润滑型式/Lubrication	不需要					
轴承/Bearing	滑动轴承, 滚珠导向轴承					
接管口径/Port size	M5x0.8					1/8

## 特性/Characteristic

- 1、执行企业标准;
- 2、2倍输出力, 抵抗侧面负载力强;
- 3、滑动轴承和滚珠轴承的精度高;
- 4、不旋转精度高, 双活塞选择;
- 5、薄小型双杆气缸带高精度导向单元, 可用于排选和顺位工作场合;
- 6、轻型设计磁性开关;
- 7、可调整行程。

\* 如需润滑, 请用透平1号油。

## 符号/Mark

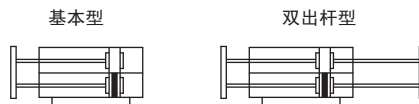

## 订购码/Ordering NO.

**KCXS M 20 - 30 DX32 S**

- 轴承种类**  
M: 滑动轴承  
L: 滚珠轴承
- 缸径**
- 行程**
- 磁性开关**  
无记号: 无磁性开关  
DX32 : 规格详见A-166
- 磁性开关个数**  
无记号: 2个  
S: 1个  
N: n个

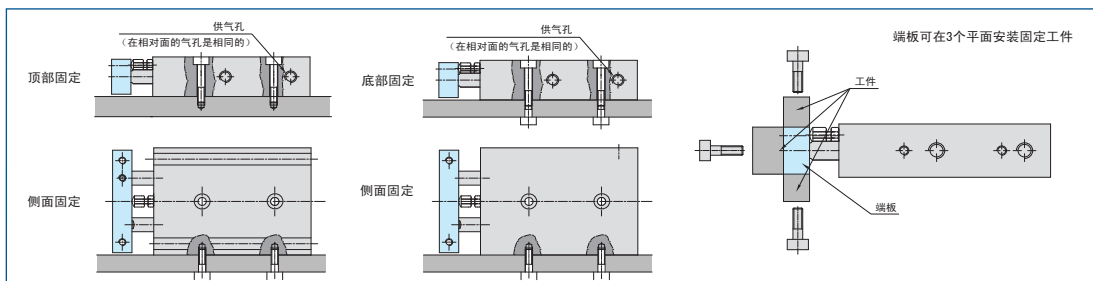

## 双轴气缸/Dual-rod cylinder

### 行程/Stroke

内径 (mm)	标准行程 (mm)	最大行程	容许行程	磁性开关
6	10 20 30 40 50	50	70	DX-32
10	10 15 20 25 30 35 40 45 50 55 60 70 75	75	100	
15	10 15 20 25 30 35 40 45 50 55 60 70 75 80 90 100	100	200	
20				
25				
32				

### 内部结构/Assembly Chart

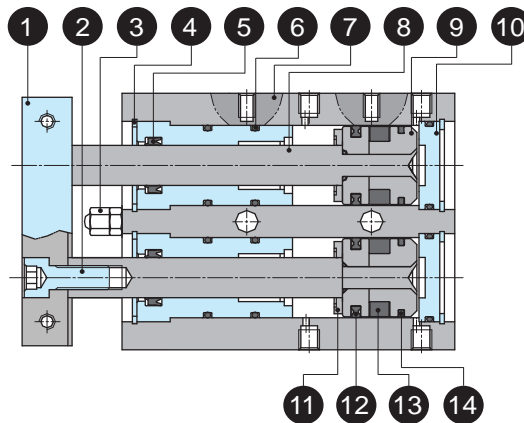

序号	零件名称	序号	零件名称	序号	零件名称	序号	零件名称	序号	零件名称
1	端板	4	弹性挡圈	7	缸体	10	后盖	13	磁环
2	内六角螺栓	5	杆密封圈	8	活塞杆	11	防撞垫	14	耐磨环
3	缓冲螺栓	6	O型圈	9	活塞	12	活塞密封圈		

### 主要零件材质/Material Quality

零件名称	材质	零件名称	材质	零件名称	材质
端板	铝合金	活塞密封圈	NBR	防撞垫	TPU
缸体	铝合金	杆密封圈	NBR	弹性挡圈	弹簧钢
后盖	铝合金	O型圈	NBR	六角螺母	碳钢
活塞	铝合金	磁环	稀土类	活塞杆	S45C镀硬铬



KCXS

## 双轴气缸 / Dual-rod cylinder

### 外部规格 / Dimensions

#### KCXS6 series

##### ■ 基本型

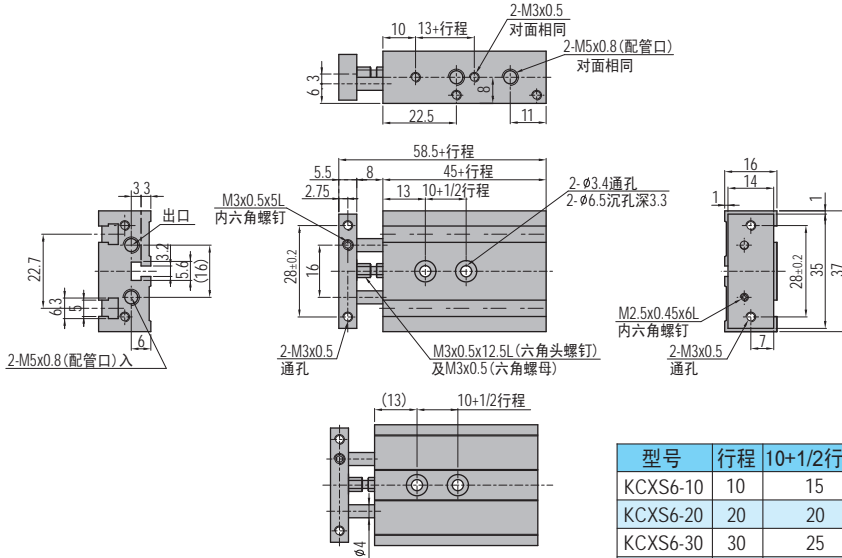

型号	行程	10+1/2行程	13+行程	45+行程	58.5+行程
KCXS6-10	10	15	23	55	68.5
KCXS6-20	20	20	33	65	78.5
KCXS6-30	30	25	43	75	88.5
KCXS6-40	40	30	53	85	98.5
KCXS6-50	50	35	63	95	108.5

#### KCXS10/15/20/25/32 series

##### ■ 基本型

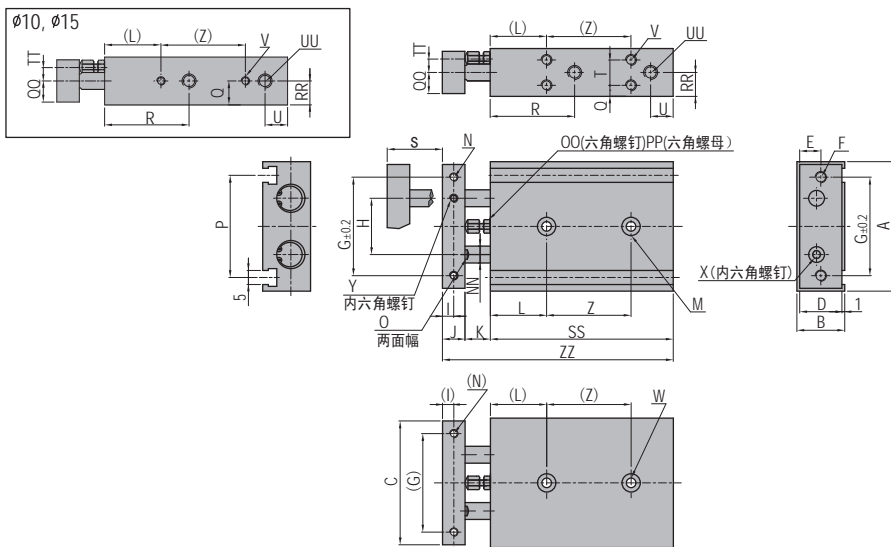

## 双轴气缸 / Dual-rod cylinder

### 外部规格 / Dimensions

#### KCXS10~32 series

##### ■ 基本型

型号	A	B	C	D	E	F	G	H	I	J	K	L	M	N	NN	O	OO	P	PP	Q	QQ	R	RR	S	SS
KCXS10-10																								10	65
KCXS10-20																								20	75
KCXS10-30	46	17	44	15	7.5	2-M4x0.7 (通孔)	35	20	4	8	9	20	2-φ3.4 (通孔)	2-M3x0.5 螺纹深度:5	6	5	M4x0.7 x14.5L	33.6	M4x0.7	8.5	7	30	7	30	85
KCXS10-40																								40	95
KCXS10-50																								50	105
KCXS15-10																								10	70
KCXS15-20																								20	80
KCXS15-30	58	20	56	18	9	2-M5x0.8 (通孔)	45	25	5	10	9	30	2-φ4.3 (通孔)	2-M4x0.7 螺纹深度:6	8	6	M4x0.7 x14.5L	48	M4x0.7	10	10	38.5	10	30	90
KCXS15-40																								40	100
KCXS15-50																								50	110
KCXS20-10																								10	80
KCXS20-20																								20	90
KCXS20-30																								30	100
KCXS20-40	64	25	62	23	11.5	2-M5x0.8 (通孔)	50	28	6	12	12	30	2-φ5.5 (通孔) 2-φ9.5 沉孔深度: 5.3	2-M4x0.7 螺纹深度:6	10	8	M6x1.0 x18.5L	53	M6x1.0	7.75	12.5	45	7.75	50	120
KCXS20-50																								75	145
KCXS20-75																								100	170
KCXS20-100																								100	170
KCXS25-10																								10	82
KCXS25-20																								20	92
KCXS25-30																								30	102
KCXS25-40	80	30	78	28	14	2-M6x1.0 (通孔)	60	35	6	12	12	30	2-φ6.9 (通孔) 2-φ11 沉孔深度: 6.3	2-M5x0.8 螺纹深度:7.5	12	10	M6x1.0 x18.5L	64	M6x1.0	8.5	15	46	15	40	112
KCXS25-50																								50	122
KCXS25-75																								75	147
KCXS25-100																								100	172
KCXS32-10																								10	92
KCXS32-20																								20	102
KCXS32-30																								30	112
KCXS32-40	98	38	96	36	18	2-M6x1.0 (通孔)	75	44	8	16	14	30	2-φ6.9 (通孔) 2-φ11 沉孔深度: 6.3	2-M5x0.8 螺纹深度:8	16	13	M8x1.25 x23L	76	M8x1.25	9	19	56	19	40	122
KCXS32-50																								50	132
KCXS32-75																								75	157
KCXS32-100																								100	182

型号	T	TT	U	UU	V	W	X	Y	Z	ZZ	型号	T	TT	U	UU	V	W	X	Y	Z	ZZ			
KCXS10-10											KCXS25-10											30	106	
KCXS10-20											KCXS25-20												92	116
KCXS10-30	-	5	8	4-M5x0.8 螺纹深度 4.5 (进气口) (对面相同)	4-M3x0.5 螺纹深度 4.5 (对面相同)	2-M4x0.7 螺纹深度 7	M3x 0.5	M5x 0.8	30	82	KCXS25-30	13	9	9	4-1/8 螺纹深度 6.5 (进气口) (对面相同)	8-M5x0.8 螺纹深度 7.5 (对面相同)	2-M8x1.25 螺纹深度 12	M6x 1.0	M8x 1.25	40	126			
KCXS10-40											KCXS25-40											40	136	
KCXS10-50											KCXS25-50											40	146	
KCXS15-10											KCXS25-75											60	171	
KCXS15-20											KCXS25-100											60	196	
KCXS15-30	-	5	8	4-M5x0.8 螺纹深度 4.5 (进气口) (对面相同)	4-M4x0.7 螺纹深度 5 (对面相同)	2-M5x0.8 螺纹深度 8	M5x 0.8	M6x 1.0	25	89	KCXS32-10											40	122	
KCXS15-40											KCXS32-20											40	132	
KCXS15-50											KCXS32-30											40	142	
KCXS20-10											KCXS32-40	20	11.5	10	4-1/8 螺纹深度 6.5 (进气口) (对面相同)	8-M5x0.8 螺纹深度 7.5 (对面相同)	2-M8x1.25 螺纹深度 12	M8x 1.25	M10 x1.5	50	152			
KCXS20-20											KCXS32-50											50	162	
KCXS20-30											KCXS32-75											70	187	
KCXS20-40	9.5	6.5	8	4-M5x0.8 螺纹深度 4.5 (进气口) (对面相同)	8-M4x0.7 螺纹深度 6 (对面相同)	2-M6x1.0 螺纹深度 10	M6x 1.0	M8x 1.25	40	134	KCXS32-100											70	212	
KCXS20-50																								
KCXS20-75																								
KCXS20-100																								



KCXS

## 双轴气缸 / Dual-rod cylinder (双出杆型)

### 外部规格 / Dimensions

#### KCXSW6 series

##### ■ 基本型

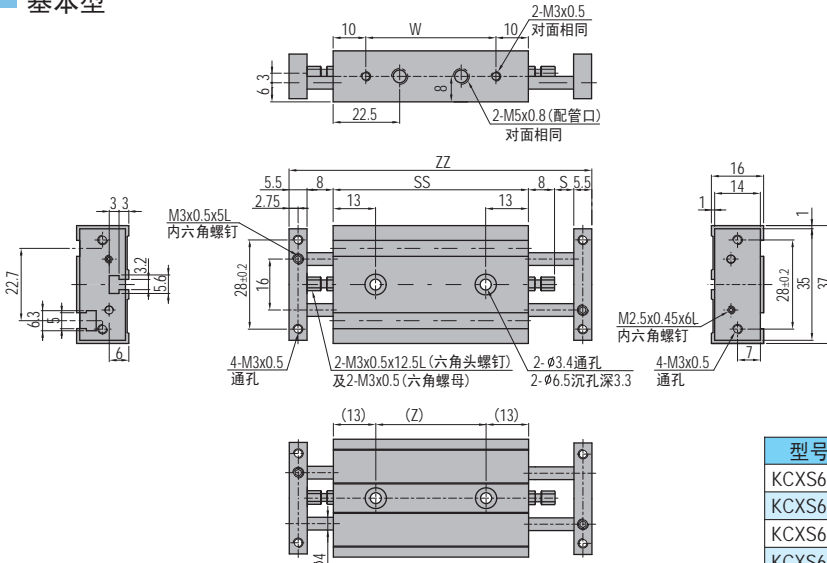

型号	S	SS	ZZ	Z	W
KCXSW6-10	10	66	103	40	46
KCXSW6-20	20	76	123	50	56
KCXSW6-30	30	86	143	60	66
KCXSW6-40	40	96	163	70	76
KCXSW6-50	50	106	183	80	86

#### KCXSW10 series

##### ■ 基本型

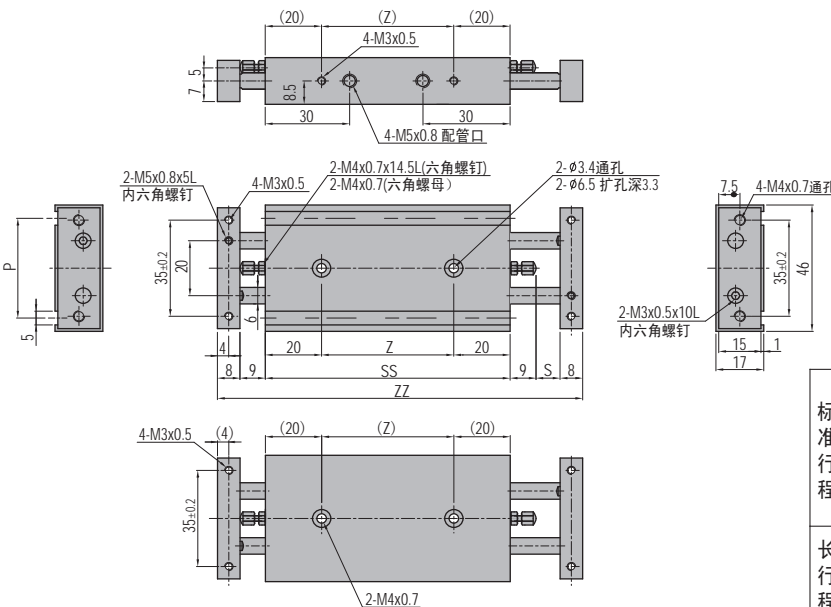

	型号	S	SS	ZZ	Z
标准行程	KCXSW10-10	10	92	136	52
	KCXSW10-20	20	102	156	62
	KCXSW10-30	30	112	176	72
	KCXSW10-40	40	122	196	82
	KCXSW10-50	50	132	216	92
长行程	KCXSW10-75	75	157	266	117
	KCXSW10-100	100	182	316	142
	KCXSW10-125	125	207	366	167
	KCXSW10-150	150	232	416	192

## 双轴气缸 / Dual-rod cylinder (双出杆型)

### 外部规格 / Dimensions

#### KCXSW15 series

##### ■ 基本型

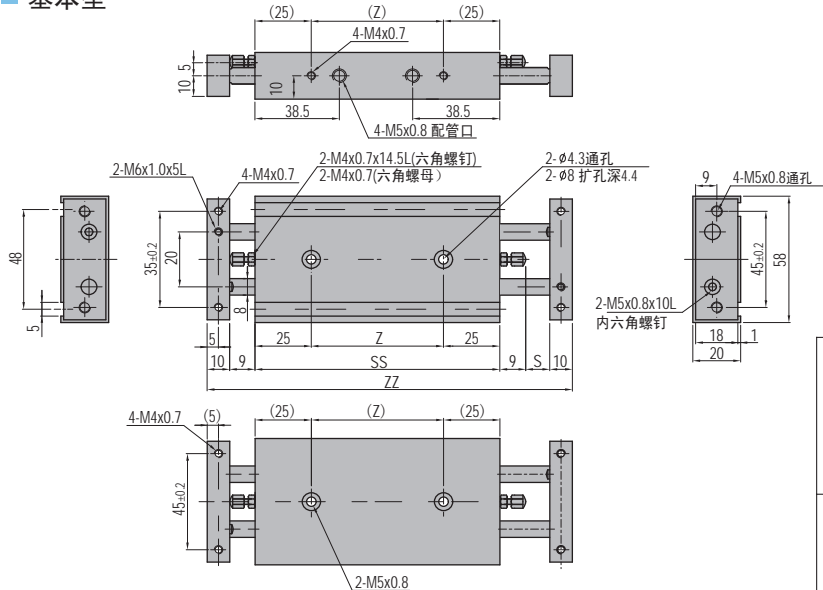

	型号	S	SS	ZZ	Z
标准行程	KCXSW15-10	10	105	153	55
	KCXSW15-20	20	115	173	65
	KCXSW15-30	30	125	193	75
	KCXSW15-40	40	135	213	85
	KCXSW15-50	50	145	233	95
长行程	KCXSW15-75	75	170	283	120
	KCXSW15-100	100	195	333	145
	KCXSW15-125	125	220	383	170
	KCXSW15-150	150	245	433	195

#### KCXSW20 series

##### ■ 基本型

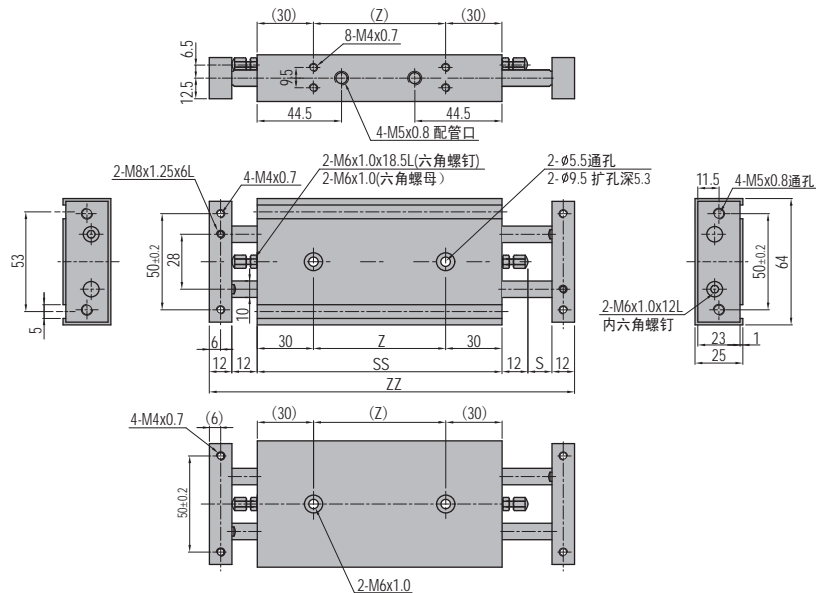

	型号	S	SS	ZZ	Z
标准行程	KCXSW20-10	10	120	178	60
	KCXSW20-20	20	130	198	70
	KCXSW20-30	30	140	218	80
	KCXSW20-40	40	150	238	90
	KCXSW20-50	50	160	258	100
长行程	KCXSW20-75	75	185	308	125
	KCXSW20-100	100	210	358	150
	KCXSW20-125	125	235	408	175
	KCXSW20-150	150	260	458	200
	KCXSW20-175	175	285	508	225
KCXSW20-200	200	310	558	250	



KCXSW

## 双轴气缸 / Dual-rod cylinder (双出杆型)

### 外部规格 / Dimensions

#### KCXSW25 series

##### ■ 基本型

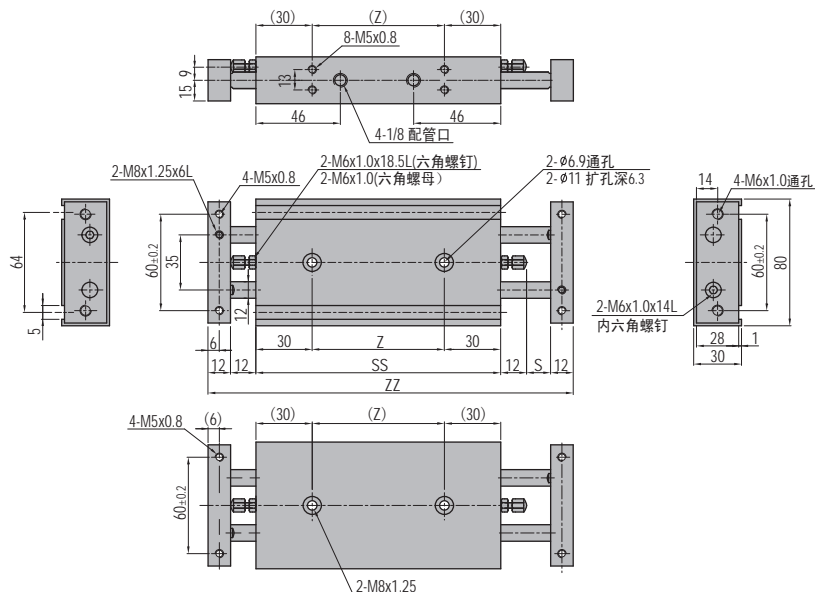

	型号	S	SS	ZZ	Z
标准行程	KCXSW25-10	10	122	180	62
	KCXSW25-20	20	132	200	72
	KCXSW25-30	30	142	220	82
	KCXSW25-40	40	152	240	92
	KCXSW25-50	50	162	260	102
长行程	KCXSW25-75	75	187	310	127
	KCXSW25-100	100	212	360	152
	KCXSW25-125	125	237	410	177
	KCXSW25-150	150	262	460	202
	KCXSW25-175	175	287	510	227
	KCXSW25-200	200	312	560	252

#### KCXSW32 series

##### ■ 基本型

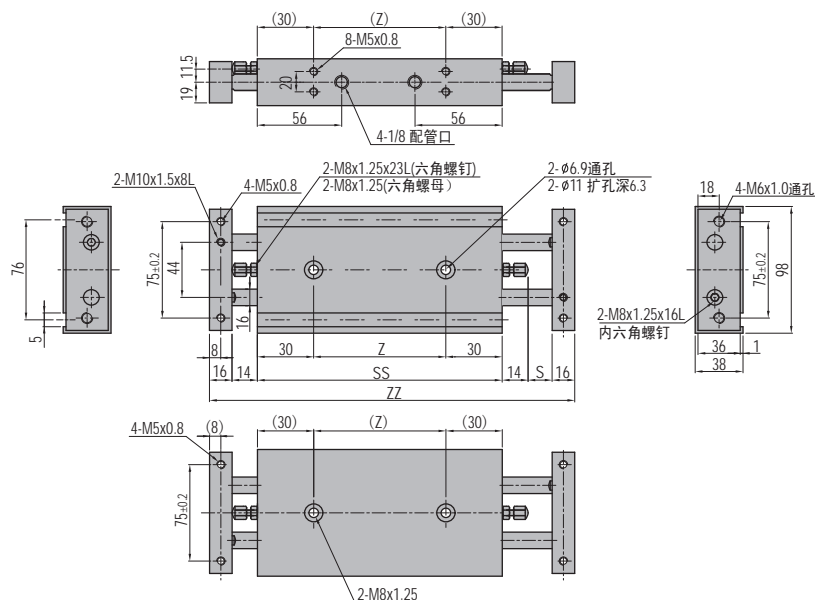

	型号	S	SS	ZZ	Z
标准行程	KCXSW32-10	10	143	213	83
	KCXSW32-20	20	153	233	93
	KCXSW32-30	30	163	253	103
	KCXSW32-40	40	173	273	113
	KCXSW32-50	50	183	293	123
长行程	KCXSW32-75	75	208	343	148
	KCXSW32-100	100	233	393	173
	KCXSW32-125	125	258	443	198
	KCXSW32-150	150	283	493	223
	KCXSW32-175	175	308	543	248
	KCXSW32-200	200	333	593	273