

KSA series

超薄型气缸/ Ultra compact cylinder

φ12 φ16 φ20 φ25 φ32 φ40 φ50 φ63 φ80 φ100

规格/Specification

内径 (mm)	12	16	20	25	32	40	50	63	80	100
작동方式/Acting	双动型/单动型									
工作介质/Fluids	洁净空气									
使用压力/Pressure range	双动0.1MPa、单动0.2MPa									
耐压力/Pressure-resistance	0.9MPa									
工作温度/Fluids temp	-5~+70℃									
速度范围/Speed range	双动30~800 mm/s、单动50~800 mm/s									
行程公差/Stroke tolerance	+1.4 0 mm									
缓冲型式/Cushion type	无									
润滑型式/Lubrication	不需要									
接管口径/Port size	M5x0.8			1/8		1/4		3/8		

* 如需润滑, 请用透平1号油。

特性/Characteristic

- 1、标准型气缸;
- 2、缸体与后盖, 活塞与活塞杆采用铆合结构, 紧凑可靠;
- 3、缸体内径滚压处理后再做硬质氧化处理, 耐磨、耐久性好;
- 4、活塞密封采用异形双向密封结构, 尺寸紧凑, 有储油功能;
- 5、紧凑型结构, 能有效节省安装空间;
- 6、缸体周边带有磁感应开关槽, 安装、感应开关方便;
- 7、多种规格安装附件可供选择。

符号/Mark



订购码/Ordering NO.

KS D A W B 20 - 50 D M - CS1-J S - XC16

内置磁环
无记号: 无内置磁环
D: 内置磁环

缸径

行程

缸身 (任选)

无记号: 杆端内螺纹
M: 杆端外螺纹

磁性开关个数

无记号: 2个
S: 1个
N: n个

类型

无记号: 单活塞杆
W: 双活塞杆

安装形式

B: 通孔
A: 两端内螺纹
L: 脚座型
F: 杆侧法兰型
G: 无杆侧法兰型
D: 双U型钩型

动作方式

D: 双动
S: 单动 (弹簧压回)
T: 单动 (弹簧压出)

磁性开关

无记号: 无磁性开关
CS1-J: 规格详见

型号

无记号: 标准型
XC8: 行程可调型 (伸出型)
XC10: 双行程/双活塞杆型
XC11: 双行程/单活塞杆型
XC16: 无铜离子型



超薄型气缸/Ultra compact cylinder

行程/Stroke

内径 (mm)	标准行程 (mm)		最大行程	容许行程	磁性开关
	双动	单动			
12	5 10 15 20 25 30 35 40 45 50 55 60	5 10 15 20 25 30	65	80	CSI-J
16	5 10 15 20 25 30 35 40 45 50 55 60	5 10 15 20 25 30			
20	5 10 15 20 25 30 35 40 45 50 55 60 65 70 75 80 85 90 95 100	5 10 15 20 25 30	100	130	
25	5 10 15 20 25 30 35 40 45 50 55 60 65	5 10 15 20 25 30			
32	70 75 80 85 90 95 100 110 120 130	5 10 15 20 25 30	130	150	
40	70 75 80 85 90 95 100 110 120 130	5 10 15 20 25 30			
50	70 75 80 85 90 95 100 110 120 130	5 10 15 20 25 30			
63	70 75 80 85 90 95 100 110 120 130	5 10 15 20 25 30	130	150	
80	75 80 85 90 95 100 110 120 130	-			
100	75 80 85 90 95 100 110 120 130	-	130	150	

内部结构/Assembly Chart

■ KSA series/不附磁型

■ KSDA series/附磁型

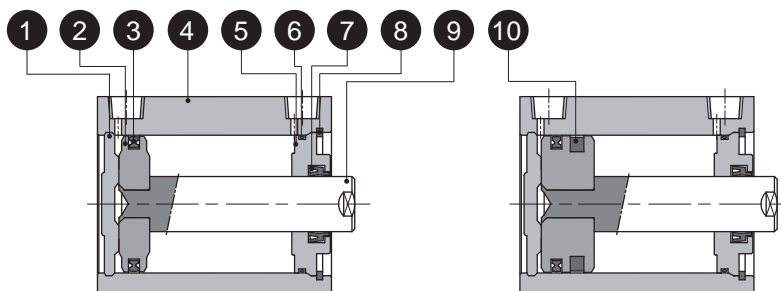

序号	零件名称	序号	零件名称
1	后盖	6	O型圈
2	活塞	7	杆密封圈
3	活塞密封圈	8	弹性挡圈
4	缸体	9	活塞杆
5	前盖	10	磁环

主要零件材质/Material Quality

零件名称	材质	零件名称	材质
前、后盖	铝合金	活塞密封圈	NBR
活塞杆	S45C镀硬铬	杆密封圈	NBR
缸筒	铝合金	O型圈	NBR
活塞	铝合金	磁环	塑胶

超薄型气缸/Ultra compact cylinder (基本型)

外部规格/Dimensions

KS (D) AB12~16 series

■ 基本型

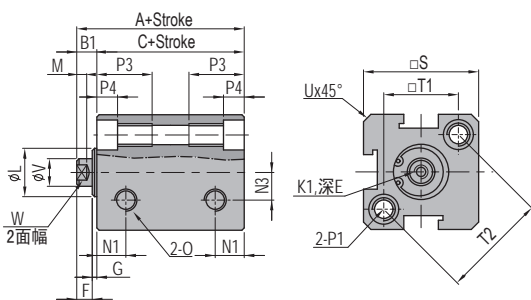

KS (D) AB20~100 series

■ 基本型

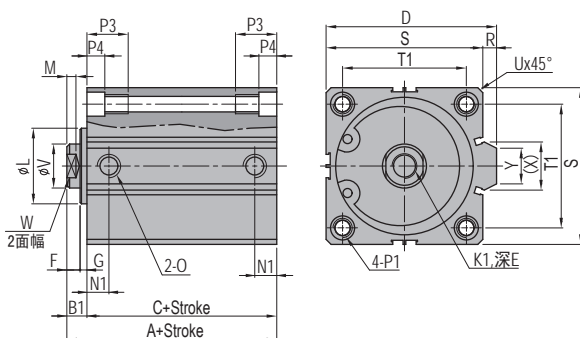

缸径 (mm)	不附磁			附磁			D	E		F	G	K1	L	M	N1	N3	O
	A	B1	C	A	B1	C		行程≤10	行程>10								
12	22	5	17	32	5	27	-	6	4	1	M3x0.5	10.2	2.8	6.3	6	M5x0.8	
16	24	5.5	18.5	34	5.5	28.5	-	6	4	1.5	M3x0.5	11	2.8	7.3	6.5	M5x0.8	
20	25	5.5	19.5	35	5.5	29.5	36	8	4	1.5	M4x0.7	15	2.8	7.5	-	M5x0.8	
25	27	6	21	37	6	31	42	10	4	2	M5x0.8	17	2.8	8	-	M5x0.8	
32	31.5	7	24.5	41.5	7	34.5	50	12	4	3	M6x1.0	22	2.8	9	-	1/8	
40	33	7	26	43	7	36	58.5	12	4	3	M8x1.25	28	2.8	10	-	1/8	
50	37	9	28	47	9	38	71.5	15	5	4	M10x1.5	38	2.8	10.5	-	1/4	
63	41	9	32	51	9	42	84.5	15	5	4	M10x1.5	40	2.8	12	-	1/4	
80	52	11	41	62	11	51	104	15	6	5	M14x1.5	45	4	14.5	-	3/8	
100	63	12	51	73	12	61	124	18	7	5	M18x1.5	55	4	20.5	-	3/8	
缸径 (mm)	P1						P3	P4	R	S	T1	T2	U	V	W	X	Y
12	沉孔:φ6.5, 螺纹:M5x0.8, 通孔:φ4.2						12	4.5	-	25	16.2	23	1.6	6	5	-	-
16	沉孔:φ6.5, 螺纹:M5x0.8, 通孔:φ4.2						12	4.5	-	29	19.8	28	1.6	6	5	-	-
20	沉孔:φ6.5, 螺纹:M5x0.8, 通孔:φ4.2						14	4.5	2	34	24	-	2.1	8	6	11.3	10
25	沉孔:φ8.2, 螺纹:M6x1.0, 通孔:φ4.6						15	5.5	2	40	28	-	3.1	10	8	12	10
32	沉孔:φ8.2, 螺纹:M6x1.0, 通孔:φ4.6						16	5.5	6	44	34	-	2.15	12	10	18.3	15
40	沉孔:φ10, 螺纹:M8x1.25, 通孔:φ6.5						20	7.5	6.5	52	40	-	2.25	16	14	21.3	16
50	沉孔:φ11, 螺纹:M8x1.25, 通孔:φ6.5						25	8.5	9.5	62	48	-	4.15	20	17	30	20
63	沉孔:φ11, 螺纹:M8x1.25, 通孔:φ6.5						25	8.5	9.5	75	60	-	3.15	20	17	28.7	20
80	沉孔:φ14, 螺纹:M12x1.75, 通孔:φ9.2						25	10.5	10	94	74	-	3.65	25	22	36	26
100	沉孔:φ17.5, 螺纹:M14x2.0, 通孔:φ11.3						30	13	10	114	90	-	3.65	32	27	35	26

超薄型气缸 / Ultra compact cylinder (单动压回型)

外部规格 / Dimensions

KS (D) AB12~16-S series

■ 单动压回型

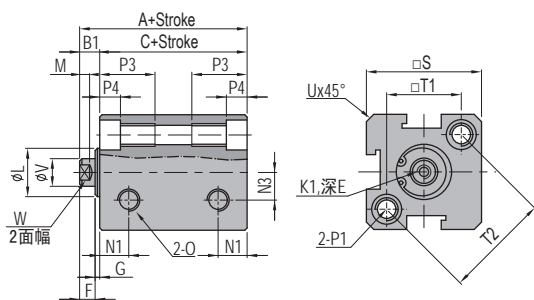

KS (D) AB20~40-S series

■ 单动压回型

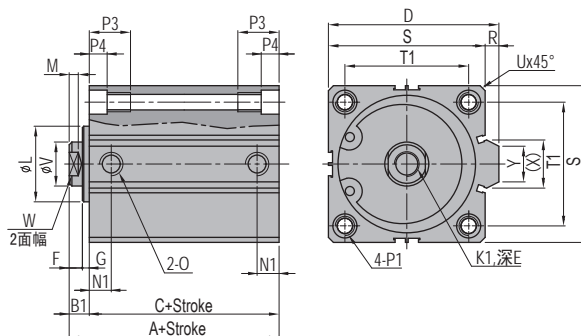

缸径 (mm)	不附磁						附磁						D	E	F	G	K1	L	M	N1	N3	O
	A		B1	C		A		B1	C													
	≤10	>10		≤10	>10	≤10	>10		≤10	>10												
12	32	42	5	27	37	42	52	5	37	47	-	6	4	1	M3x0.5	10.2	2.8	6.3	6	-	M5x0.8	
16	34	44	5.5	28.5	38.5	44	54	5.5	38.5	48.5	-	6	4	1.5	M3x0.5	11	2.8	7.3	6.5	-	M5x0.8	
20	35	45	5.5	29.5	39.5	45	55	5.5	39.5	49.5	36	8	4	1.5	M4x0.7	15	2.8	7.5	-	-	M5x0.8	
25	37	47	6	31	41	47	57	6	41	51	42	10	4	2	M5x0.8	17	2.8	8	-	-	M5x0.8	
32	41.5	51.5	7	34.5	44.5	51.5	61.5	7	44.5	54.5	50	12	4	3	M6x1.0	22	2.8	9	-	-	1/8	
40	43	53	7	36	46	53	63	7	46	56	58.5	12	4	3	M8x1.25	28	2.8	10	-	-	1/8	
缸径 (mm)	P1					P3	P4	R	S	T1	T2	U	V	W	X	Y						
12	沉孔:φ6.5, 螺纹:M5x0.8, 通孔:φ4.2					12	4.5	-	25	16.2	23	1.6	6	5	-	-						
16	沉孔:φ6.5, 螺纹:M5x0.8, 通孔:φ4.2					12	4.5	-	29	19.8	28	1.6	6	5	-	-						
20	沉孔:φ6.5, 螺纹:M5x0.8, 通孔:φ4.2					14	4.5	2	34	24	-	2.1	8	6	11.3	10						
25	沉孔:φ8.2, 螺纹:M6x1.0, 通孔:φ4.6					15	5.5	2	40	28	-	3.1	10	8	12	10						
32	沉孔:φ8.2, 螺纹:M6x1.0, 通孔:φ4.6					16	5.5	6	44	34	-	2.15	12	10	18.3	15						
40	沉孔:φ10, 螺纹:M8x1.25, 通孔:φ6.5					20	7.5	6.5	52	40	-	2.25	16	14	21.3	16						

超薄型气缸/Ultra compact cylinder (单动压出型)

外部规格/Dimensions

KS (D) AB12~16-T series

■ 单动压出型

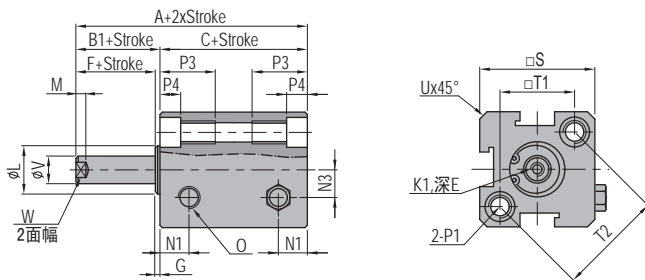

KS (D) AB20~40-T series

■ 单动压出型

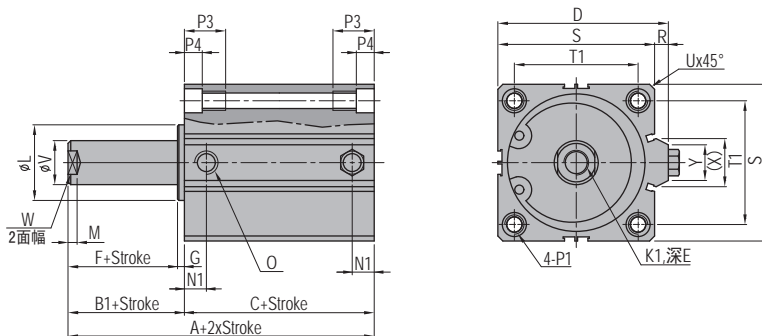

缸径 (mm)	不附磁						附磁						D	E	F	G	K1	L	M	N1	N3	O
	A		B1	C		A		B1	C													
	≤10	>10		≤10	>10	≤10	>10		≤10	>10												
12	32	42	5	27	37	42	52	5	37	47	-	6	4	1	M3x0.5	10.2	2.8	6.3	6	M5x0.8		
16	34	44	5.5	28.5	38.5	44	54	5.5	38.5	48.5	-	6	4	1.5	M3x0.5	11	2.8	7.3	6.5	M5x0.8		
20	35	45	5.5	29.5	39.5	45	55	5.5	39.5	49.5	36	8	4	1.5	M4x0.7	15	2.8	7.5	-	M5x0.8		
25	37	47	6	31	41	47	57	6	41	51	42	10	4	2	M5x0.8	17	2.8	8	-	M5x0.8		
32	41.5	51.5	7	34.5	44.5	51.5	61.5	7	44.5	54.5	50	12	4	3	M6x1.0	22	2.8	9	-	1/8		
40	43	53	7	36	46	53	63	7	46	56	58.5	12	4	3	M8x1.25	28	2.8	10	-	1/8		
缸径 (mm)	P1				P3	P4	R	S	T1	T2	U	V	W	X	Y							
12	沉孔:φ6.5, 螺纹:M5x0.8, 通孔:φ4.2				12	4.5	-	25	16.2	23	1.6	6	5	-	-							
16	沉孔:φ6.5, 螺纹:M5x0.8, 通孔:φ4.2				12	4.5	-	29	19.8	28	1.6	6	5	-	-							
20	沉孔:φ6.5, 螺纹:M5x0.8, 通孔:φ4.2				14	4.5	2	34	24	-	2.1	8	6	11.3	10							
25	沉孔:φ8.2, 螺纹:M6x1.0, 通孔:φ4.6				15	5.5	2	40	28	-	3.1	10	8	12	10							
32	沉孔:φ8.2, 螺纹:M6x1.0, 通孔:φ4.6				16	5.5	6	44	34	-	2.15	12	10	18.3	15							
40	沉孔:φ10, 螺纹:M8x1.25, 通孔:φ6.5				20	7.5	6.5	52	40	-	2.25	16	14	21.3	16							

超薄型气缸/Ultra compact cylinder (杆端外螺纹型)

外部规格/Dimensions

KS(D) AB12~16 series

■ 杆端外螺纹型

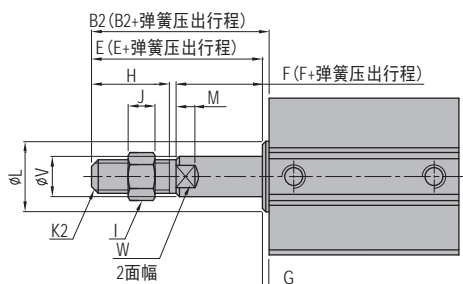

KS(D) AB20~100 series

■ 杆端外螺纹型

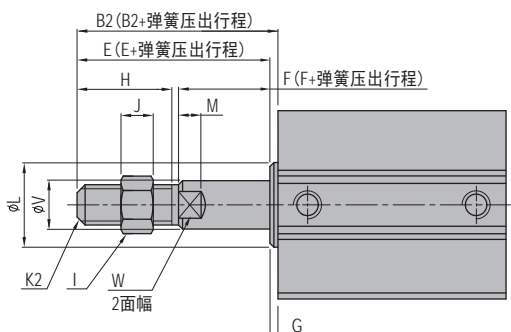

缸径 (mm)	B2	E	F	G	H	I	J	K2	L	M	V	W
12	17	16	4	1	10	8	4	M5x0.8	10.2	2.8	6	5
16	17.5	16	4	1.5	10	8	4	M5x0.8	11	2.8	6	5
20	20.5	19	4	1.5	13	10	5	M6x1.0	15	2.8	8	6
25	23	21	4	2	15	12	6	M8x1.25	17	2.8	10	8
32	25	22	4	3	15	17	6	M10x1.25	22	2.8	12	10
40	35	32	4	3	25	19	8	M14x1.5	28	2.8	16	14
50	37	33	5	4	25	27	11	M18x1.5	38	2.8	20	17
63	37	33	5	4	25	27	11	M18x1.5	40	2.8	20	17
80	44	39	6	5	30	32	13	M22x1.5	45	4	25	22
100	50	45	7	5	35	36	13	M26x1.5	55	4	32	27



KSA

超薄型气缸/Ultra compact cylinder (双杆型)

外部规格/Dimensions

KSAW12~16 series

■ 双活塞杆型

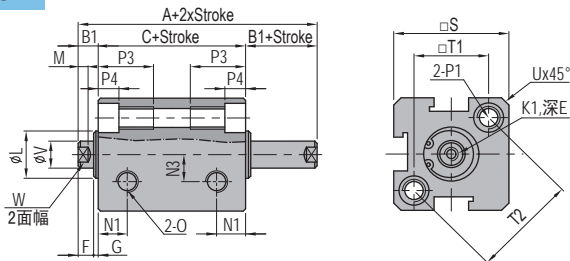

KSAW20~100 series

■ 双活塞杆型

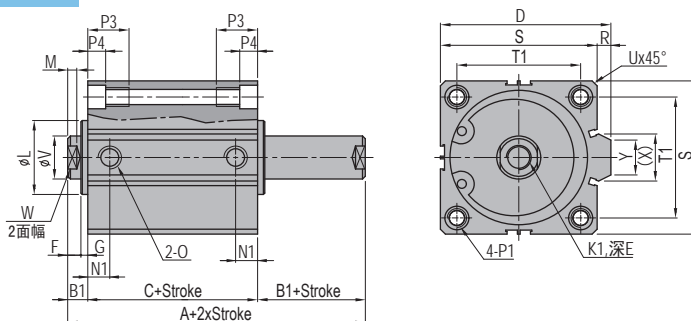

缸径 (mm)	不附磁			附磁			D	E		F	G	K1	L	M	N1	N3	O
	A	B1	C	A	B1	C		行程≤10	行程>10								
12	27	5	17	37	5	27	-	6	4	1	M3x0.5	10.2	2.8	6.3	6	M5x0.8	
16	29.5	5.5	18.5	39.5	5.5	28.5	-	6	4	1.5	M3x0.5	11	2.8	7.3	6.5	M5x0.8	
20	30.5	5.5	19.5	40.5	5.5	29.5	36	8 (行程=5时为6.5)	4	1.5	M4x0.7	15	2.8	7.5	-	M5x0.8	
25	33	6	21	43	6	31	42	10 (行程=5时为7)	4	2	M5x0.8	17	2.8	8	-	M5x0.8	
32	38.5	7	24.5	48.5	7	34.5	50	8	4	3	M6x1.0	22	2.8	9	-	1/8	
40	40	7	26	50	7	36	58.5	8	4	3	M8x1.25	28	2.8	10	-	1/8	
50	46	9	28	56	9	38	71.5	8	5	4	M10x1.5	38	2.8	10.5	-	1/4	
63	50	9	32	60	9	42	84.5	10	5	4	M10x1.5	40	2.8	12	-	1/4	
80	63	11	41	73	11	51	104	13	6	5	M14x1.5	45	4	14.5	-	3/8	
100	75	12	51	85	12	61	124	18	7	5	M18x1.5	55	4	20.5	-	3/8	
缸径 (mm)	P1						P3	P4	R	S	T1	T2	U	V	W	X	Y
12	沉孔:φ6.5, 螺纹:M5x0.8, 通孔:φ4.2						12	4.5	-	25	16.2	23	1.6	6	5	-	-
16	沉孔:φ6.5, 螺纹:M5x0.8, 通孔:φ4.2						12	4.5	-	29	19.8	28	1.6	6	5	-	-
20	沉孔:φ6.5, 螺纹:M5x0.8, 通孔:φ4.2						14	4.5	2	34	24	-	2.1	8	6	11.3	10
25	沉孔:φ8.2, 螺纹:M6x1.0, 通孔:φ4.6						15	5.5	2	40	28	-	3.1	10	8	12	10
32	沉孔:φ8.2, 螺纹:M6x1.0, 通孔:φ4.6						16	5.5	6	44	34	-	2.15	12	10	18.3	15
40	沉孔:φ10, 螺纹:M8x1.25, 通孔:φ6.5						20	7.5	6.5	52	40	-	2.25	16	14	21.3	16
50	沉孔:φ11, 螺纹:M8x1.25, 通孔:φ6.5						25	8.5	9.5	62	48	-	4.15	20	17	30	20
63	沉孔:φ11, 螺纹:M8x1.25, 通孔:φ6.5						25	8.5	9.5	75	60	-	3.15	20	17	28.7	20
80	沉孔:φ14, 螺纹:M12x1.75, 通孔:φ9.2						25	10.5	10	94	74	-	3.65	25	22	36	26
100	沉孔:φ17.5, 螺纹:M14x2.0, 通孔:φ11.3						30	13	10	114	90	-	3.65	32	27	35	26

超薄型气缸/Ultra compact cylinder (伸出可调行程型)

外部规格/Dimensions

KS (D) A12~16-XC8 series

■ 伸出可调行程型

KS (D) A 安装形式 缸径 - 行程 -

调节范围 - XC8

0 ≤ Stroke < 25 调节范围 0 - 10mm

25 ≤ Stroke < 50 调节范围 0 - 25mm

Stroke ≥ 50 调节范围 0 - 50mm

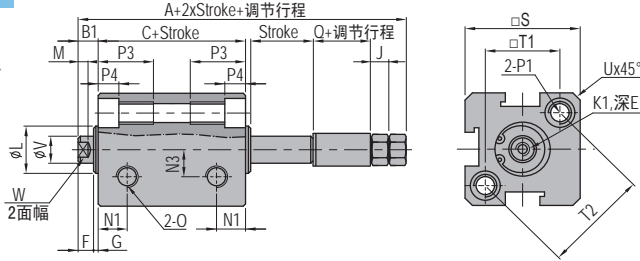

KS (D) A20~100-XC8 series

■ 伸出可调行程型

KS (D) A 安装形式 缸径 - 行程 -

调节范围 - XC8

0 ≤ Stroke < 25 调节范围 0 - 10mm

25 ≤ Stroke < 50 调节范围 0 - 25mm

Stroke ≥ 50 调节范围 0 - 50mm

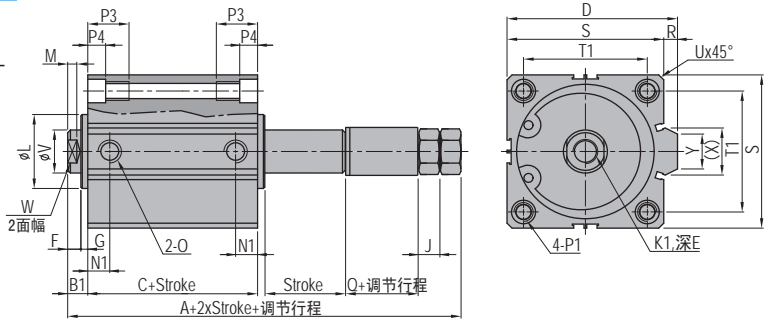

缸径 (mm)	不附磁			附磁			D	E		F	G	J	K1	L	M	N1	N3	O	
	A	B1	C	A	B1	C		行程 ≤ 10	行程 > 10										
12	40	5	17	50	5	27	-	6	6	4	1	4	M3x0.5	10.2	2.8	6.3	6	M5x0.8	
16	42.5	5.5	18.5	52.5	5.5	28.5	-	6	6	4	1.5	4	M3x0.5	11	2.8	7.3	6.5	M5x0.8	
20	47.5	5.5	19.5	57.5	5.5	29.5	36	8 (行程=5时为6.5)	8	4	1.5	5	M4x0.7	15	2.8	7.5	-	M5x0.8	
25	55	6	21	65	6	31	42	10 (行程=5时为7)	10	4	2	6	M5x0.8	17	2.8	8	-	M5x0.8	
32	61.5	7	24.5	71.5	7	34.5	50	8	12	4	3	6	M6x1.0	22	2.8	9	-	1/8	
40	65	7	26	75	7	36	58.5	8	12	4	3	8	M8x1.25	28	2.8	10	-	1/8	
50	73	9	28	83	9	38	71.5	8	15	5	4	11	M10x1.5	38	2.8	10.5	-	1/4	
63	77	9	32	87	9	42	84.5	10	15	5	4	11	M10x1.5	40	2.8	12	-	1/4	
80	94	11	41	104	11	51	104	13	20	6	5	13	M14x1.5	45	4	14.5	-	3/8	
100	105	12	51	115	12	61	124	18	20	7	5	13	M18x1.5	55	4	20.5	-	3/8	
缸径 (mm)	P1						P3	P4	Q	R	S	T1	T2	U	V	W	X	Y	
12	沉孔: φ6.5, 螺纹: M5x0.8, 通孔: φ4.2						12	4.5	13	-	25	16.2	23	1.6	6	5	-	-	-
16	沉孔: φ6.5, 螺纹: M5x0.8, 通孔: φ4.2						12	4.5	13	-	29	19.8	28	1.6	6	5	-	-	-
20	沉孔: φ6.5, 螺纹: M5x0.8, 通孔: φ4.2						14	4.5	16	2	34	24	-	2.1	8	6	11.3	10	
25	沉孔: φ8.2, 螺纹: M6x1.0, 通孔: φ4.6						15	5.5	19	2	40	28	-	3.1	10	8	12	10	
32	沉孔: φ8.2, 螺纹: M6x1.0, 通孔: φ4.6						16	5.5	21	6	44	34	-	2.15	12	10	18.3	15	
40	沉孔: φ10, 螺纹: M8x1.25, 通孔: φ6.5						20	7.5	21	6.5	52	40	-	2.25	16	14	21.3	16	
50	沉孔: φ11, 螺纹: M8x1.25, 通孔: φ6.5						25	8.5	21	9.5	62	48	-	4.15	20	17	30	20	
63	沉孔: φ11, 螺纹: M8x1.25, 通孔: φ6.5						25	8.5	21	9.5	75	60	-	3.15	20	17	28.7	20	
80	沉孔: φ14, 螺纹: M12x1.75, 通孔: φ9.2						25	10.5	24	10	94	74	-	3.65	25	22	36	26	
100	沉孔: φ17.5, 螺纹: M14x2.0, 通孔: φ11.3						30	13	24	10	114	90	-	3.65	32	27	35	26	

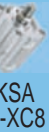

KSA-XC8

超薄型气缸 (双行程/双活塞杆型) / Ultra compact cylinder

外部规格/Dimensions

KS (D) AB12~16-XC10 series

■ 双行程双活塞杆型

KS (D) AB ϕ 缸径 - 行程1 + 行程2 - XC10

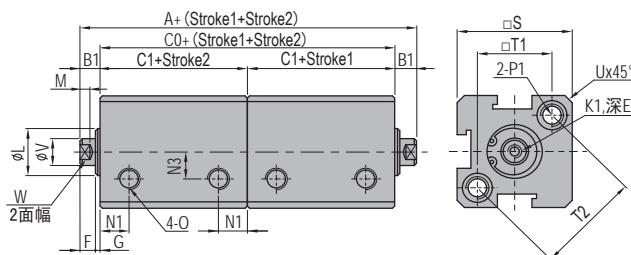

KS (D) AB20~100-XC10 series

■ 双行程双活塞杆型

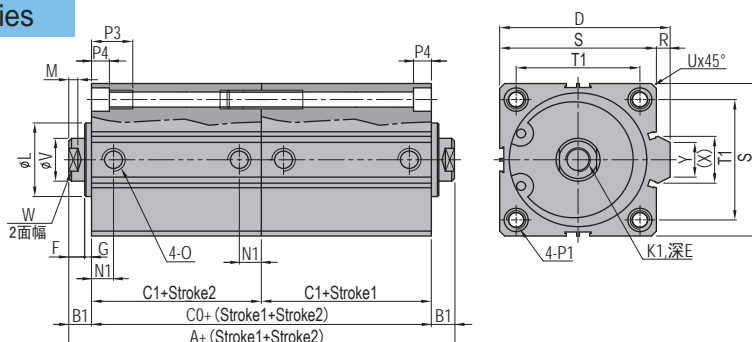

缸径 (mm)	不附磁				附磁				D	E		F	G	K1	L	M	N1	N3	O	Y
	A	B1	C0	C1	A	B1	C0	C1		行程≤10	行程>10									
12	44	5	34	17	64	5	54	27	-	6	4	1	M3x0.5	10.2	2.8	6.3	6	M5x0.8	-	
16	48	5.5	37	18.5	68	5.5	57	28.5	-	6	4	1.5	M3x0.5	11	2.8	7.3	6.5	M5x0.8	-	
20	50	5.5	39	19.5	70	5.5	59	29.5	36	8	4	1.5	M4x0.7	15	2.8	7.5	-	M5x0.8	10	
25	54	6	42	21	74	6	62	31	42	10	4	2	M5x0.8	17	2.8	8	-	M5x0.8	10	
32	63	7	49	24.5	83	7	69	34.5	50	12	4	3	M6x1.0	22	2.8	9	-	1/8	15	
40	66	7	52	26	86	7	72	36	58.5	12	4	3	M8x1.25	28	2.8	10	-	1/8	16	
50	74	9	56	28	94	9	76	38	71.5	15	5	4	M10x1.5	38	2.8	10.5	-	1/4	20	
63	82	9	64	32	102	9	84	42	84.5	15	5	4	M10x1.5	40	2.8	12	-	1/4	20	
80	104	11	82	41	124	11	102	51	104	15	6	5	M14x1.5	45	4	14.5	-	3/8	26	
100	126	12	102	51	146	12	122	61	124	18	7	5	M18x1.5	55	4	20.5	-	3/8	26	
缸径 (mm)	P1				P2				P3	P4	R	S	T1	T2	U	V	W	X		
12	沉孔:φ6.5, 螺纹:M5x0.8, 通孔:φ4.2								-	12	4.5	-	25	16.2	23	1.6	6	5	-	
16	沉孔:φ6.5, 螺纹:M5x0.8, 通孔:φ4.2								-	12	4.5	-	29	19.8	28	1.6	6	5	-	
20	沉孔:φ6.5, 螺纹:M5x0.8, 通孔:φ4.2				沉孔:φ6.5, 通孔:φ4.2				14	4.5	2	34	24	-	2.1	8	6	11.3		
25	沉孔:φ8.2, 螺纹:M6x1.0, 通孔:φ4.6				沉孔:φ8.2, 通孔:φ6.2				15	5.5	2	40	28	-	3.1	10	8	12		
32	沉孔:φ8.2, 螺纹:M6x1.0, 通孔:φ4.6				沉孔:φ8.2, 通孔:φ6.2				16	5.5	6	44	34	-	2.15	12	10	18.3		
40	沉孔:φ10, 螺纹:M8x1.25, 通孔:φ6.5				沉孔:φ10, 通孔:φ8.2				20	7.5	6.5	52	40	-	2.25	16	14	21.3		
50	沉孔:φ11, 螺纹:M8x1.25, 通孔:φ6.5				沉孔:φ11, 通孔:φ8.5				25	8.5	9.5	62	48	-	4.15	20	17	30		
63	沉孔:φ11, 螺纹:M8x1.25, 通孔:φ6.5				沉孔:φ11, 通孔:φ8.5				25	8.5	9.5	75	60	-	3.15	20	17	28.7		
80	沉孔:φ14, 螺纹:M12x1.75, 通孔:φ9.2				沉孔:φ14, 通孔:φ12.3				25	10.5	10	94	74	-	3.65	25	22	36		
100	沉孔:φ17.5, 螺纹:M14x2.0, 通孔:φ11.3				沉孔:φ17.5, 通孔:φ14.2				30	13	10	114	90	-	3.65	32	27	35		

超薄型气缸 (双行程/单活塞杆型) / Ultra compact cylinder

外部规格/Dimensions

KS (D) AB12~16-XC11 series

■ 双行程单活塞杆型

KS (D) AB **缸径** - **行程1** + **行程2** - XC11

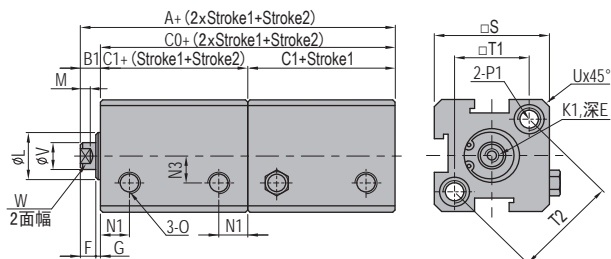

KS (D) AB20~100-XC11 series

■ 双行程单活塞杆型

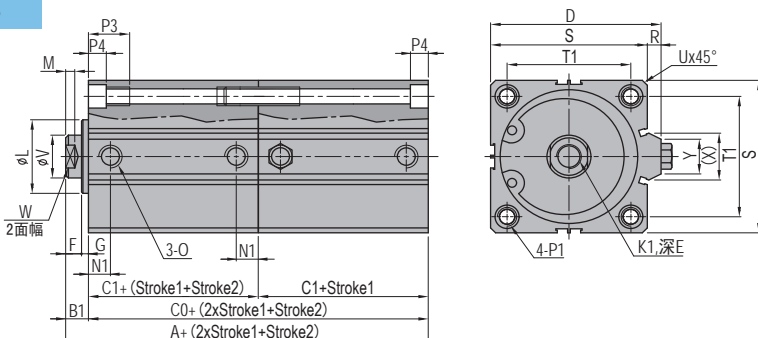

缸径 (mm)	不附磁				附磁				D	E		F	G	K1	L	M	N1	N3	O	Y
	A	B1	C0	C1	A	B1	C0	C1		行程≤10	行程>10									
12	39	5	34	17	59	5	54	27	-	6	4	1	M3x0.5	10.2	2.8	6.3	6	M5x0.8	-	
16	42.5	5.5	37	18.5	62.5	5.5	57	28.5	-	6	4	1.5	M3x0.5	11	2.8	7.3	6.5	M5x0.8	-	
20	44.5	5.5	39	19.5	64.5	5.5	59	29.5	36	8	4	1.5	M4x0.7	15	2.8	7.5	-	M5x0.8	10	
25	48	6	42	21	68	6	62	31	42	10	4	2	M5x0.8	17	2.8	8	-	M5x0.8	10	
32	56	7	49	24.5	76	7	69	34.5	50	12	4	3	M6x1.0	22	2.8	9	-	1/8	15	
40	59	7	52	26	79	7	72	36	58.5	12	4	3	M8x1.25	28	2.8	10	-	1/8	16	
50	65	9	56	28	85	9	76	38	71.5	15	5	4	M10x1.5	38	2.8	10.5	-	1/4	20	
63	73	9	64	32	93	9	84	42	84.5	15	5	4	M10x1.5	40	2.8	12	-	1/4	20	
80	93	11	82	41	113	11	102	51	104	15	6	5	M14x1.5	45	4	14.5	-	3/8	26	
100	114	12	102	51	134	12	122	61	124	18	7	5	M18x1.5	55	4	20.5	-	3/8	26	
缸径 (mm)	P1				P2				P3	P4	R	S	T1	T2	U	V	W	X		
12	沉孔:φ6.5, 螺纹:M5x0.8, 通孔:φ4.2				-				12	4.5	-	25	16.2	23	1.6	6	5	-		
16	沉孔:φ6.5, 螺纹:M5x0.8, 通孔:φ4.2				-				12	4.5	-	29	19.8	28	1.6	6	5	-		
20	沉孔:φ6.5, 螺纹:M5x0.8, 通孔:φ4.2				沉孔:φ6.5, 通孔:φ4.2				14	4.5	2	34	24	-	2.1	8	6	11.3		
25	沉孔:φ8.2, 螺纹:M6x1.0, 通孔:φ4.6				沉孔:φ8.2, 通孔:φ6.2				15	5.5	2	40	28	-	3.1	10	8	12		
32	沉孔:φ8.2, 螺纹:M6x1.0, 通孔:φ4.6				沉孔:φ8.2, 通孔:φ6.2				16	5.5	6	44	34	-	2.15	12	10	18.3		
40	沉孔:φ10, 螺纹:M8x1.25, 通孔:φ6.5				沉孔:φ10, 通孔:φ8.2				20	7.5	6.5	52	40	-	2.25	16	14	21.3		
50	沉孔:φ11, 螺纹:M8x1.25, 通孔:φ6.5				沉孔:φ11, 通孔:φ8.5				25	8.5	9.5	62	48	-	4.15	20	17	30		
63	沉孔:φ11, 螺纹:M8x1.25, 通孔:φ6.5				沉孔:φ11, 通孔:φ8.5				25	8.5	9.5	75	60	-	3.15	20	17	28.7		
80	沉孔:φ14, 螺纹:M12x1.75, 通孔:φ9.2				沉孔:φ14, 通孔:φ12.3				25	10.5	10	94	74	-	3.65	25	22	36		
100	沉孔:φ17.5, 螺纹:M14x2.0, 通孔:φ11.3				沉孔:φ17.5, 通孔:φ14.2				30	13	10	114	90	-	3.65	32	27	35		



KSA-XC11